

WHA

Ground source water to water heat pumps

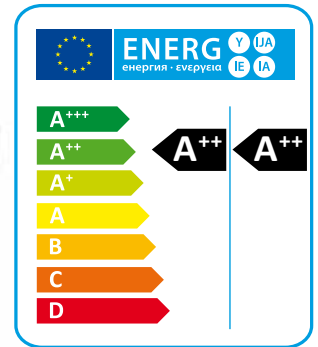

WHA heat pumps are particularly suitable for applications that utilise ground source probes. These units have been designed for use with radiant floor heating systems or those applications where it is necessary to have maximum efficiency when heating. They have been optimized on heating mode and are able to produce water up to 60°C.

WHA heat pumps are available in several versions. The most simple is a 2 pipe unit that can provide heating only. By fitting an external 3 port valve the unit can provide either heating or domestic hot water. There is also a 4 pipe unit that produces domestic hot water in a separate hydraulic circuit and can generate this irrespective of whether the unit is in heating or cooling mode. All the WHA units are also available in Free Cooling (FC) versions which provide low energy cooling by simply using the cool water that is available from either the ground source probes or the well water.

Differing versions and a wide range of accessories, enable the optimal solution to be selected.

Versions

- Standard, heating only.
- RV** Reversible heating/cooling.
- SW5** Heating only + domestic hot water circuit.
- RV/SW6** Reversible version heating/cooling with independent DHW circuit.
- FC** Free cooling version (available in all versions).

Heating only version (HH)

HH		039	045	050	060	070	080	090	110	120
Heating capacity (EN14511) ⁽¹⁾	kW	51,7	59,0	71,2	80,0	92,5	105,9	120,8	136,1	152,0
Input power (EN14511) ⁽¹⁾	kW	9,8	11,0	12,5	14,3	16,9	19,4	22,2	24,9	28,3
COP (EN14511) ⁽¹⁾	W/W	5,27	5,36	5,69	5,59	5,47	5,45	5,44	5,46	5,37
Energy Class in low temperature ⁽²⁾		A+++	A+++	A+++	A+++	A+++	A+++	A+++	A+++	A+++
SCOP low temperature ⁽²⁾	kWh/kWh	5,21	5,52	5,51	5,77	5,60	5,50	5,44	5,44	5,46
η _{s,h} low temperature ⁽²⁾	%	200,4	212,8	212,5	222,9	215,8	212,0	209,4	209,5	210,5
Energy Class in medium temperature ⁽²⁾		A+++	A+++	A+++	A+++	A+++	A+++	A+++	A+++	A+++
SCOP medium temperature ⁽²⁾	kWh/kWh	4,32	4,50	4,51	4,67	4,54	4,51	4,45	4,47	4,48
η _{s,h} medium temperature ⁽²⁾	%	164,6	171,8	172,4	178,6	173,4	172,4	170,0	170,8	171,1
Power supply	V/Ph/Hz	400/3/50	400/3/50	400/3/50	400/3/50	400/3/50	400/3/50	400/3/50	400/3/50	400/3/50
Peak current	A	111,0	132,0	140,0	143,0	199,0	208,0	259,0	265,0	312,0
Max input current	A	32,0	42,0	44,0	50,0	59,0	68,0	74,0	80,0	88,5
Compressors / Circuits	n°/n°	2/1	2/1	2/1	2/1	2/1	2/1	2/1	2/1	2/1
Capacity steps	n°	2	2	2	2	2	2	2	2	2
Global warming potential (GWP)		2088	2088	2088	2088	2088	2088	2088	2088	2088
Refrigerant charge	kg	4,3	4,3	5,0	5,0	6,0	6,5	8,0	11,0	11,0
Equivalent CO ₂ charge	t	9,0	9,0	10,4	10,4	12,5	13,6	16,7	23,0	23,0
Sound power ⁽⁴⁾	dB(A)	71	77	77	78	79	80	83	85	87
Sound pressure ⁽⁵⁾	dB(A)	55	61	61	62	63	64	66	68	70

HH		130	152	162	190	210	240	260	300	320
Heating capacity (EN14511) ⁽¹⁾	kW	169,2	195,0	222,1	243,8	271,3	306,9	342,2	390,9	439,4
Input power (EN14511) ⁽¹⁾	kW	31,6	36,8	41,0	45,1	51,0	57,3	63,6	72,5	81,4
COP (EN14511) ⁽¹⁾	W/W	5,35	5,29	5,41	5,40	5,32	5,35	5,38	5,39	5,39
Energy Class in low temperature ⁽²⁾		A+++	A+++	A+++	A+++	A+++	A+++	A+++	A+++	A+++
SCOP low temperature ⁽²⁾	kWh/kWh	5,42	5,49	5,64	5,47	5,45	5,47	5,51	5,55	5,49
η _{s,h} low temperature ⁽²⁾	%	208,8	211,7	217,6	210,6	209,9	210,6	212,5	214,1	211,6
Energy Class in medium temperature ⁽²⁾		A+++	A+++	A+++	A+++	A+++	A+++	A+++	A+++	A+++
SCOP medium temperature ⁽²⁾	kWh/kWh	4,50	4,53	4,62	4,53	4,54	4,55	4,58	4,60	4,59
η _{s,h} medium temperature ⁽²⁾	%	171,8	173,0	176,7	173,2	173,5	173,9	175,0	175,8	175,4
Power supply	V/Ph/Hz	400/3/50	400/3/50	400/3/50	400/3/50	400/3/50	400/3/50	400/3/50	400/3/50	400/3/50
Peak current	A	320,5	358,5	375,4	333,0	345,0	400,5	417,5	472,4	506,2
Max input current	A	97,0	113,9	130,8	148,0	160,0	177,0	194,0	227,8	261,6
Compressors / Circuits	n°/n°	2/1	2/1	2/1	4/2	4/2	4/2	4/2	4/2	4/2
Capacity steps	n°	2	2	2	4	4	4	4	4	4
Global warming potential (GWP)		2088	2088	2088	2088	2088	2088	2088	2088	2088
Refrigerant charge	kg	15,0	15,0	15,0	16,0	16,0	19,0	19,0	30,0	30,0
Equivalent CO ₂ charge	t	31,3	31,3	31,3	33,4	33,4	39,7	39,7	62,6	62,6
Sound power ⁽⁴⁾	dB(A)	88	88	88	86	88	90	91	91	91
Sound pressure ⁽⁵⁾	dB(A)	71	71	71	69	71	73	74	74	74

Performances are referred to the following conditions:

- (1) Heating: user water temperature 30/35°C, source water temperature 10/7°C.
 (2) Average conditions, variable - Reg EU 811/2013

(3) Sound power level in accordance with ISO 3744. Operation mode 1, without water pumps.

(4) Sound pressure level at 1 mt from the unit in free field conditions in accordance with ISO 3744. Operation mode 1, without water pumps.

Reversible heating/cooling version (RV)

RV		039	045	050	060	070	080	090	110	120
Heating capacity (EN14511) ⁽¹⁾	kW	51,7	59,0	71,2	80,0	92,5	105,9	120,8	136,1	152,0
Input power (EN14511) ⁽¹⁾	kW	9,8	11,0	12,5	14,3	16,9	19,4	22,2	24,9	28,3
COP (EN14511) ⁽¹⁾	W/W	5,27	5,36	5,69	5,59	5,47	5,45	5,44	5,46	5,37
Energy Class in low temperature ⁽²⁾		A+++	A+++	A+++	A+++	A+++	A+++	A+++	A+++	A+++
SCOP low temperature ⁽²⁾	kWh/kWh	5,21	5,52	5,51	5,77	5,60	5,50	5,44	5,44	5,46
η _{s,h} low temperature ⁽²⁾	%	200,4	212,8	212,5	222,9	215,8	212,0	209,4	209,5	210,5
Energy Class in medium temperature ⁽²⁾		A+++	A+++	A+++	A+++	A+++	A+++	A+++	A+++	A+++
SCOP medium temperature ⁽²⁾	kWh/kWh	4,32	4,50	4,51	4,67	4,54	4,51	4,45	4,47	4,48
η _{s,h} medium temperature ⁽²⁾	%	164,6	171,8	172,4	178,6	173,4	172,4	170,0	170,8	171,1
Cooling capacity (EN14511) ⁽³⁾	kW	42,9	49,0	60,3	67,4	77,5	88,9	101,3	114,3	126,9
Total input power (EN14511) ⁽³⁾	kW	10,0	11,3	12,9	14,7	17,4	19,9	22,7	25,5	29,0
EER (EN14511) ⁽³⁾	W/W	4,29	4,33	4,67	4,58	4,45	4,46	4,46	4,48	4,37
Free Cooling capacity ⁽⁴⁾	kW	22,8	22,9	36,0	36,3	36,6	49,3	71,0	72,4	73,5
Power supply	V/Ph/Hz	400/3/50	400/3/50	400/3/50	400/3/50	400/3/50	400/3/50	400/3/50	400/3/50	400/3/50
Peak current	A	111,0	132,0	140,0	143,0	199,0	208,0	259,0	265,0	312,0
Max input current	A	32,0	42,0	44,0	50,0	59,0	68,0	74,0	80,0	88,5
Compressors / Circuits	n°/n°	2/1	2/1	2/1	2/1	2/1	2/1	2/1	2/1	2/1
Capacity steps	n°	2	2	2	2	2	2	2	2	2
Global warming potential (GWP)		2088	2088	2088	2088	2088	2088	2088	2088	2088
Refrigerant charge	kg	5,0	5,0	7,0	7,0	7,5	9,0	10,0	15,0	15,0
Equivalent CO ₂ charge	t	10,4	10,4	14,6	14,6	15,7	18,8	20,9	31,3	31,3
Sound power ⁽⁵⁾	dB(A)	71	77	77	78	79	80	83	85	87
Sound pressure ⁽⁶⁾	dB(A)	55	61	61	62	63	64	66	68	70

RV		130	152	162	190	210	240	260	300	320
Heating capacity (EN14511) ⁽¹⁾	kW	169,2	195,0	222,1	243,8	271,3	306,9	342,2	390,9	439,4
Input power (EN14511) ⁽¹⁾	kW	31,6	36,8	41,0	45,1	51,0	57,3	63,6	72,5	81,4
COP (EN14511) ⁽¹⁾	W/W	5,35	5,29	5,41	5,40	5,32	5,35	5,38	5,39	5,39
Energy Class in low temperature ⁽²⁾		A+++	A+++	A+++	A+++	A+++	A+++	A+++	A+++	A+++
SCOP low temperature ⁽²⁾	kWh/kWh	5,42	5,49	5,64	5,47	5,45	5,47	5,51	5,55	5,49
η _{s,h} low temperature ⁽²⁾	%	208,8	211,7	217,6	210,6	209,9	210,6	212,5	214,1	211,6
Energy Class in medium temperature ⁽²⁾		A+++	A+++	A+++	A+++	A+++	A+++	A+++	A+++	A+++
SCOP medium temperature ⁽²⁾	kWh/kWh	4,50	4,53	4,62	4,53	4,54	4,55	4,58	4,60	4,59
η _{s,h} medium temperature ⁽²⁾	%	171,8	173,0	176,7	173,2	173,5	173,9	175,0	175,8	175,4
Cooling capacity (EN14511) ⁽³⁾	kW	141,2	163,6	187,4	205,1	226,9	257,3	287,4	328,1	368,5
Total input power (EN14511) ⁽³⁾	kW	32,3	37,8	42,2	46,3	52,4	58,8	65,2	74,3	83,4
EER (EN14511) ⁽³⁾	W/W	4,37	4,32	4,44	4,43	4,33	4,37	4,40	4,41	4,41
Free Cooling capacity ⁽⁴⁾	kW	74,1	93,1	94,0	128,2	129,6	130,9	163,0	164,4	203,0
Power supply	V/Ph/Hz	400/3/50	400/3/50	400/3/50	400/3/50	400/3/50	400/3/50	400/3/50	400/3/50	400/3/50
Peak current	A	320,5	358,5	375,4	333,0	345,0	400,5	417,5	472,4	506,2
Max input current	A	97,0	113,9	130,8	148,0	160,0	177,0	194,0	227,8	261,6
Compressors / Circuits	n°/n°	2/1	2/1	2/1	4/2	4/2	4/2	4/2	4/2	4/2
Capacity steps	n°	2	2	2	4	4	4	4	4	4
Global warming potential (GWP)		2088	2088	2088	2088	2088	2088	2088	2088	2088
Refrigerant charge	kg	15,0	15,0	15,0	20,0	20,0	30,0	30,0	34,0	34,0
Equivalent CO ₂ charge	t	31,3	31,3	31,3	41,8	41,8	62,6	62,6	71,0	71,0
Sound power ⁽⁵⁾	dB(A)	88	88	88	86	88	90	91	91	91
Sound pressure ⁽⁶⁾	dB(A)	71	71	71	69	71	73	74	74	74

Performances are referred to the following conditions:

- (1) Heating: user water temperature 30/35°C, source water temperature 10/7°C.
- (2) Average conditions, variable - Reg EU 811/2013
- (3) Cooling: user water temperature 12/7°C, source water temperature 30/35°C.
- (4) Free Cooling: user water temperature 10°C, source water temperature 20°C, compressors OFF.

- (5) Sound power level in accordance with ISO 3744. Operation mode 1, without water pumps.
- (6) Sound pressure level at 1 mt from the unit in free field conditions in accordance with ISO 3744. Operation mode 1, without water pumps.

Frame

All units are made from hot-galvanised sheet steel, painted with polyurethane powder enamel and stoved at 180°C to provide maximum protection against corrosion. The frame is self-supporting with removable panels. All screws and rivets used are made from stainless steel. The standard colour of the units is RAL 9018.

Refrigerant circuit

The refrigerant utilised is R410A. The refrigerant circuit is assembled using internationally recognised brand name components with all brazing and welding being performed in accordance with ISO 97/23. Each refrigerant circuit is totally independent from the other with the result that any fault or alarm condition on one circuit does not influence the other.

The refrigerant circuit includes: sight glass, filter drier, thermal expansion valve with external equalizer, Schrader valves for maintenance and control and pressure safety device (for compliance with PED regulations).

Compressors

The compressors used are a high performance scroll type that incorporates a special scroll design which enhances the efficiency of the refrigerant cycle when the source temperature is low. The compressors are all supplied with a crankcase heater and thermal overload protection by a klixon embedded in the motor winding. They are mounted in a separate enclosure thus enabling them to be maintained even if the unit is operating. Access to this enclosure is via the front panel of the unit. The crankcase heater is always powered when the compressor is in stand-by.

Source heat exchanger

Source heat exchanger are braze-welded plates and are made of stainless steel AISI 316. From size 039 to size 162 are single-circuit, from size 190 are all double circuit cross-flow. The use of this type of exchangers greatly reduces the refrigerant charge of the unit compared to the conventional shell and tube evaporators, and increases the efficiency of the refrigerant loads. The heat exchangers are factory insulated with flexible close cell material and are protected by a temperature sensor used as anti-freeze protection kit.

User exchanger

The user side heat exchanger is a braze welded, plate type heat exchanger, manufactured from AISI 316 stainless steel. From size 039 to size 162 they have a single water side circuit, from the size 190 they are double circuit, "cross flow" type. All units are supplied with a sub-cooler to enhance the performance of the refrigerant cycle. The user heat exchangers are factory insulated with flexible close cell material.

Microprocessors

All units are supplied as standard with microprocessor controls. The microprocessor controls the following functions: control of the water temperature, antifreeze protection, compressor timing, compressor automatic starting sequence, alarm reset, volt free contact for remote general alarm, alarms and operation LED's. If required (available as an option), the microprocessor

can be configured in order for it to connect to a site BMS system thus enabling remote control and management. The technical department can discuss and evaluate, in conjunction with the customer, solutions using MODBUS protocols.

Electric enclosure

The enclosure is manufactured in order to comply with the requirements of the electromagnetic compatibility standards CEE EN60204. Access to the enclosure is achieved by removing the front panel of the unit. The following components are supplied as standard on all units: main switch, thermal overloads (protection of pumps and fans), compressor fuses, control circuit automatic breakers, compressor contactors, fan contactors and pump contactors. The terminal board has volt free contacts for remote ON-OFF, Summer/Winter change over (reversible type only) and general alarm. For all three phase units, a sequence relay that disables the power supply in the event that the phase sequence is incorrect (scroll compressors can be damaged if they rotate in the wrong direction), is fitted as standard.

Control and protection devices

All units are supplied with the following control and protection devices: Return and supply user heat exchanger sensors, return and supply source heat exchanger sensors, high pressure switch with manual reset, low pressure switch with automatic reset, high pressure safety valve, compressor thermal overload protection, pump thermal overload protection (when present), source heat exchanger flow switch.



Hydraulic kit

all units can be supplied with water pump circulation kit installed on Source, User or Recovery circuit.

Versions

WHA/RV 2 Pipe version

This version is capable of cooling during summer operation by using a 4 way reversing valve in the refrigerant circuit.

WHA/RV/SW6 4 Pipe version

This version has 4 pipes on the user side and is able to produce simultaneously, hot and cold water on 2 independent hydraulic circuits. The domestic hot water production is independent of the operation mode of the unit.

Versione free cooling

These versions, in addition to the characteristics described above, can produce cold water during summer operation using the cold water available from the source ground probes. All free cooling versions are supplied with an intermediate heat exchanger and a 3 way valve which modulates the water flow to the user circuit depending on the required user cold water temperature. During free cooling mode the compressors may be off or will operate partially to augment the free cooling available.

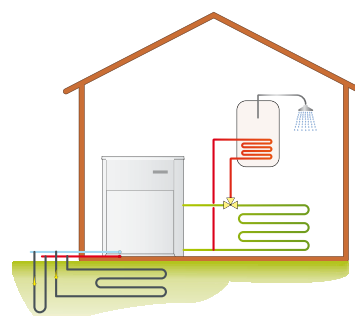

WHA/RV

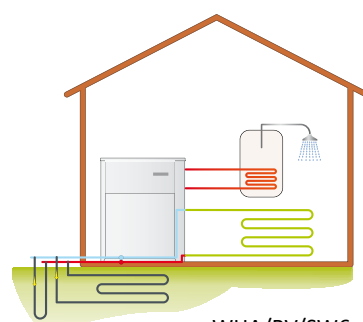

WHA/RV/SW6

Configurations *

MOD.	P2	P4	P2+FC	P4+FC	P2+A	P4+A
39	F1	F1	F1	F1	F3	F4
45	F1	F1	F1	F1	F3	F4
50	F1	F1	F1	F1	F3	F4
60	F1	F1	F1	F1	F3	F4
70	F1	F1	F1	F1	F3	F4
80	F1	F1	F1	F1	F3	F4
90	F2	F2	F2	F2	F3	F4
110	F2	F2	F2	F2	F3	F4
120	F2	F2	F2	F2	F3	F4
130	F2	F2	F2	F2	F3	F4
152	F2	F2	F2	F2	F3	F4
162	F2	F2	F2	F2	F3	F4
190	F4	F4	F5	F5	F5	F5
210	F4	F4	F5	F5	F5	F5
240	F4	F4	F5	F5	F5	F5
260	F4	F4	F5	F5	F5	F5
300	F4	F4	F5	F5	F5	F5
320	F4	F4	F5	F5	F5	F5

* Please contact sales office

Legend

P2 2 pipe system

P4 4 pipe system

P2+FC 2 pipe system with Free Cooling

P4+FC 4 pipe system with Free Cooling

P2+A 2 pipe system with hydraulic kit

P4+A 4 pipe system with hydraulic kit

WHA		039÷080	090÷110	120÷162	190÷260	300÷320
Main switch		●	●	●	●	●
Microprocessor control		●	●	●	●	●
Remote ON/OFF digital input		●	●	●	●	●
Summer/Winter digital input		●	●	●	●	●
LS low noise version [-4dB(A) of STD]	LS00	○	○	○	○	○
Electronic Soft starter	DSSE	○	○	○	○	○
Rubber anti-vibration mountings	KAVG	○	○	○	○	○
Spring anti-vibration mountings	KAVM	○	○	○	○	○
Refrigerant circuit pressure gauges	MAML	○	○	○	○	○
Liquid line solenoid valve	VSLI	○	○	○	○	○
Remote control panel	PCRL	○	○	○	○	○
Serial interface card RS485 with MODBUS protocol	INSE	●	●	●	●	●
2 way modulating to control source water consumption	V2M0	○	○	○	○	○
Electronic thermostatic valve	VTEE	○	○	○	○	○
Hydraulic kit with one pump without tank - user circuit	A1NTU	○	○	○	○	○
Hydraulic kit with one pump without tank - source circuit	A1NTS	○	○	○	○	○
Hydraulic kit with one pump without tank - recovery circuit	A1NTR	○	○	○	○	○
Hydraulic kit with two pumps without tank - user circuit	A2NTU	○	○	○	○	○
Hydraulic kit with two pumps without tank - source circuit	A2NTS	○	○	○	○	○
Hydraulic kit with two pumps without tank - recovery circuit	A2NTR	○	○	○	○	○

● Standard, ○ Optional, – Not available.

Operation limits

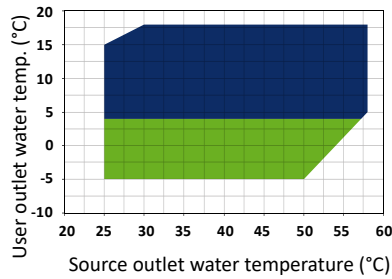
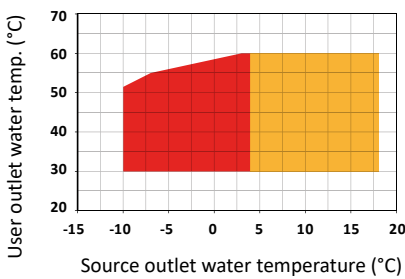

- Heating
- Heating with glycol source circuit
- Cooling
- Cooling with glycol user circuit

Operating limits with 5°C Δt

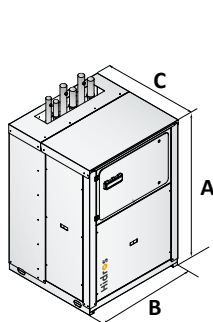

Frame 1

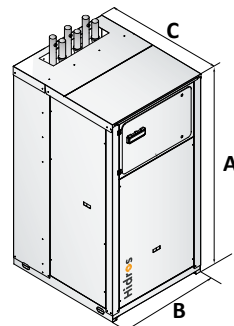

Frame 2

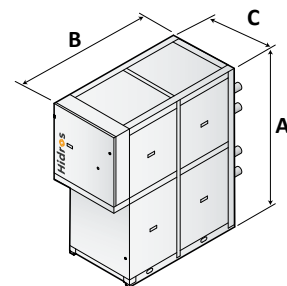

Frame 3

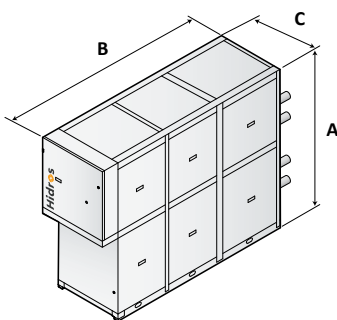

Frame 4

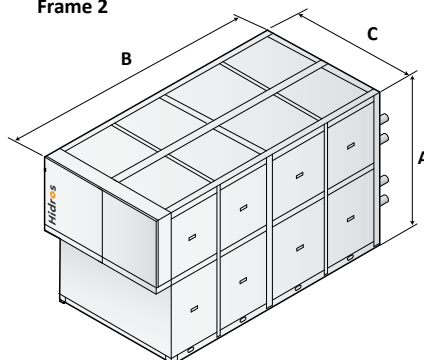

Frame 5

Mod.	A (mm)	B (mm)	C (mm)
F1	1566	1101	1005
F2	1986	1101	1255
F3	1900	2170	800
F4	1900	3120	800
F5	1730	3030	1600